

BOMBA HSX | HSX PUMP

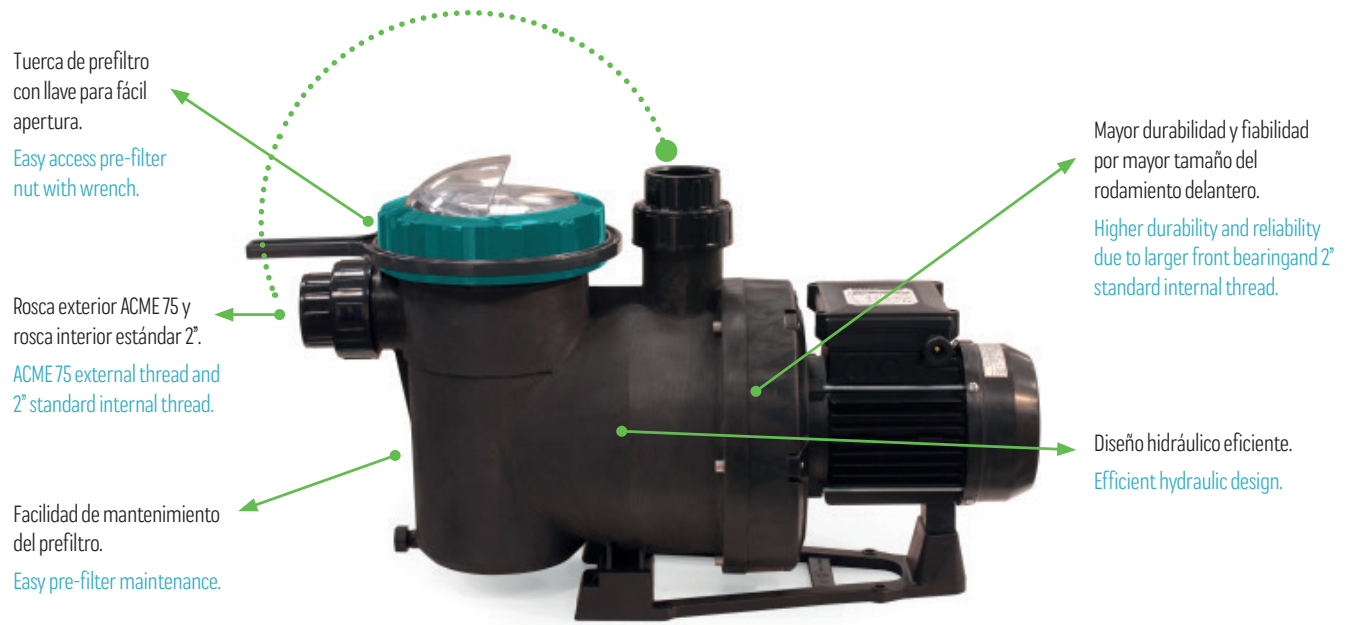

El cuerpo de la bomba está construido con **termoplásticos de última generación**.

Las bombas son autoaspirantes de **1/2 CV hasta 1,5 CV** y se proporcionan con motores monofásicos.

En el cuerpo de la bomba se ha integrado un prefiltro para evitar la entrada de objetos extraños que pudieran dañar las partes hidráulicas de la bomba. Los motores que se suministran con el conjunto motor bomba han sido protegidos con IP-55 y acondicionados para soportar ambientes calurosos y niveles de humedad elevados. Rodamiento delantero de tamaño superior para mejorar la resistencia a esfuerzos axiales.

*Compatible con bomba Victoria Plus Silent.

The body of the pump is made of the latest **generation thermoplastics**.

The pumps are Self-priming, range from **1/2 HP up to 1,5 HP** and are provided with both single-phase.

A pre-filter has been integrated into the body of the pump to prevent the entry of any foreign bodies which could cause damage to the hydraulic parts of the pump. The motors supplied with the pump unit have been protected with IP-55 protection and are adapted to withstand hot atmospheres and high humidity levels. Oversized front bearing to improve resistance to axial forces.

			HSX PUMP			
Código HSX	Code HSX		HSX50 8	HSX75 11	HSX100 16	HSX150 22
Código	Code		73470HDS	73491HDS	73492HDS	73496HDS
Potencia	Power	CV/HP	1/2 (II)	3/4 (II)	1 (II)	1 1/2 (II)
Tensión	Voltage	V	230			
H max.	H max.	m	13	14	17	18
R.P.M.	R.P.M.	-	2810	2802	2810	2800
Q nom	Q nom	m ³ /h	10	11	16	22,5
H nom	H nom	m	8	10		
Peso caja	Weight box	Kg	12	13	14	
Volumen caja	Volume box	m ³	0,07			

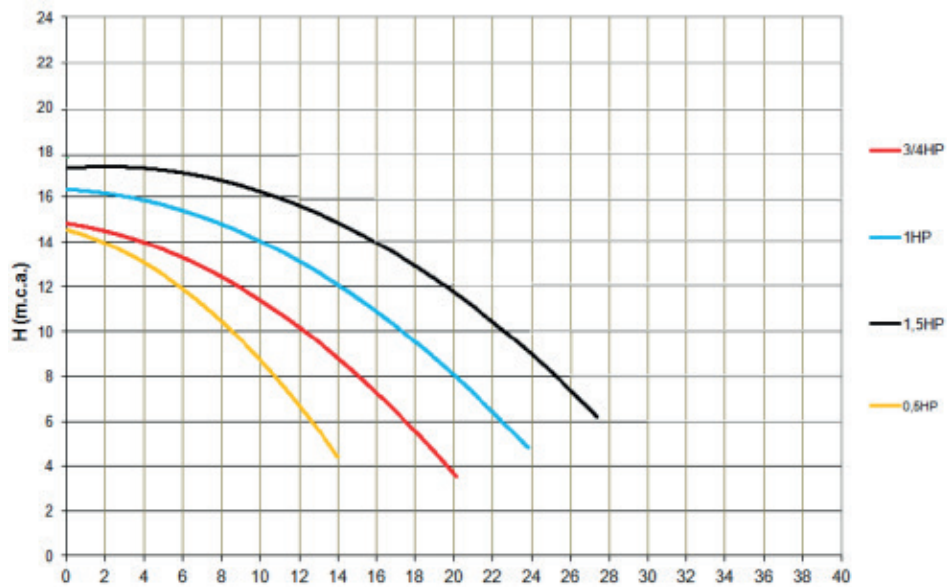

CURVAS DE RENDIMIENTO AH-Q | PERFORMANCE CURVES AH-Q 

DIMENSIONES | DIMENSIONS 

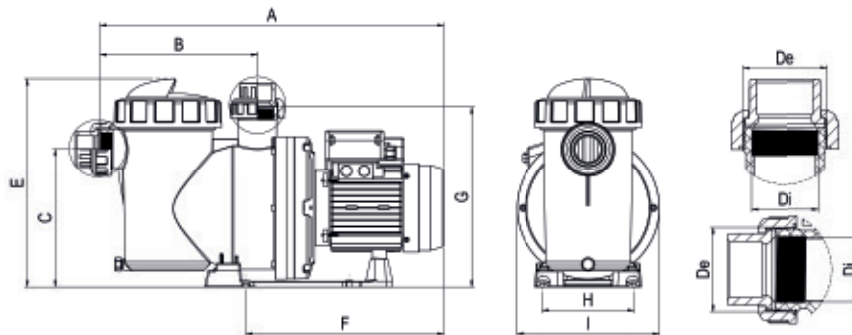

HSX PUMP															
CÓDIGO CODE	CÓDIGO HSX CODE HSX	MOTOR / MOTOR		H max. m	DIMENSIONES / DIMENSION										Ø TUBO Ø PIPE
		CV / HP	VOLTAGE V		A	B	C	De	Di	E	F	G	H	I	
73470HDS	HSX50 8	1/2	230	13	581	281	230	ACME D.75	2" GAS	372	322	32	164	254	50
73491HDS	HSX75 11	3/4		14											
73492HDS	HSX100 16	1		17											
73496HDS	HSX150 22	1 1/2		18											615